

JX-POP168

POP-168 micro. Project board

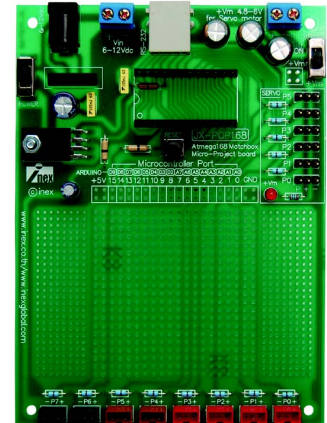

Copyright 2007-2008 Innovative Experiment Co.,Ltd., Thailand

1. Specification

- Dual female socket 12 pin for support POP-168 microcontroller module
- Prototype area 3.8" x 5" for making the circuit or small breadboard installation.
- 2 of power supply terminals
 - For POP-168 and any interfacing circuit ; use the external power supply such as DC adaptor or battery 6 to 12V 500mA (not include), on-board polarity protection circuit. Include the power switch and LED indicator.
 - For the servo motor ; support 4.8 to 6Vdc. Use 2-pin terminal block and have the power switch with LED indicator.
- On board +5Vdc regulator.
- Reset switch.
- Free pads for connecting all microcontroller port pins. They are assigned to compatible with BASIC Stamp port (P0 to P15) and Arduino microcontroller.
- Provides in 3-pin JST connector for P0 to P7 (or A0 to A7).
- 6 of Servo motor connector. They are connected with P0 to P5 of POP-168 module.
- Supplied with CX-4 cable for connecting PC's serial port.

2. Circuit Description

The full circuit shows in Figure 1, on JX-POP168 board has a blank socket for supporting the POP-168 Matchbox microcontroller board and prototype area sizes 3.8" x 5". You can apply DC voltage supply to the input DC jack or Terminal block. The supply voltage range is +7 to +16Vdc. On board provide +5V regulator circuit and reset switch.

The port of POP-168 are provided 2 types. One is free-pads of P0 to P15 included +5V and GND pads. Another one is 3-pin JST connector for P0 to P7. You can use this port to connect with INEX sensor board and serial application board such as SLCD16x2, ZX-SERVO 16, ZX-19 Sound Smart board, ZX-17 the Serial Real-time clock board and etc.

2 ● JX-POP168 : POP-168 microcontroller Project board

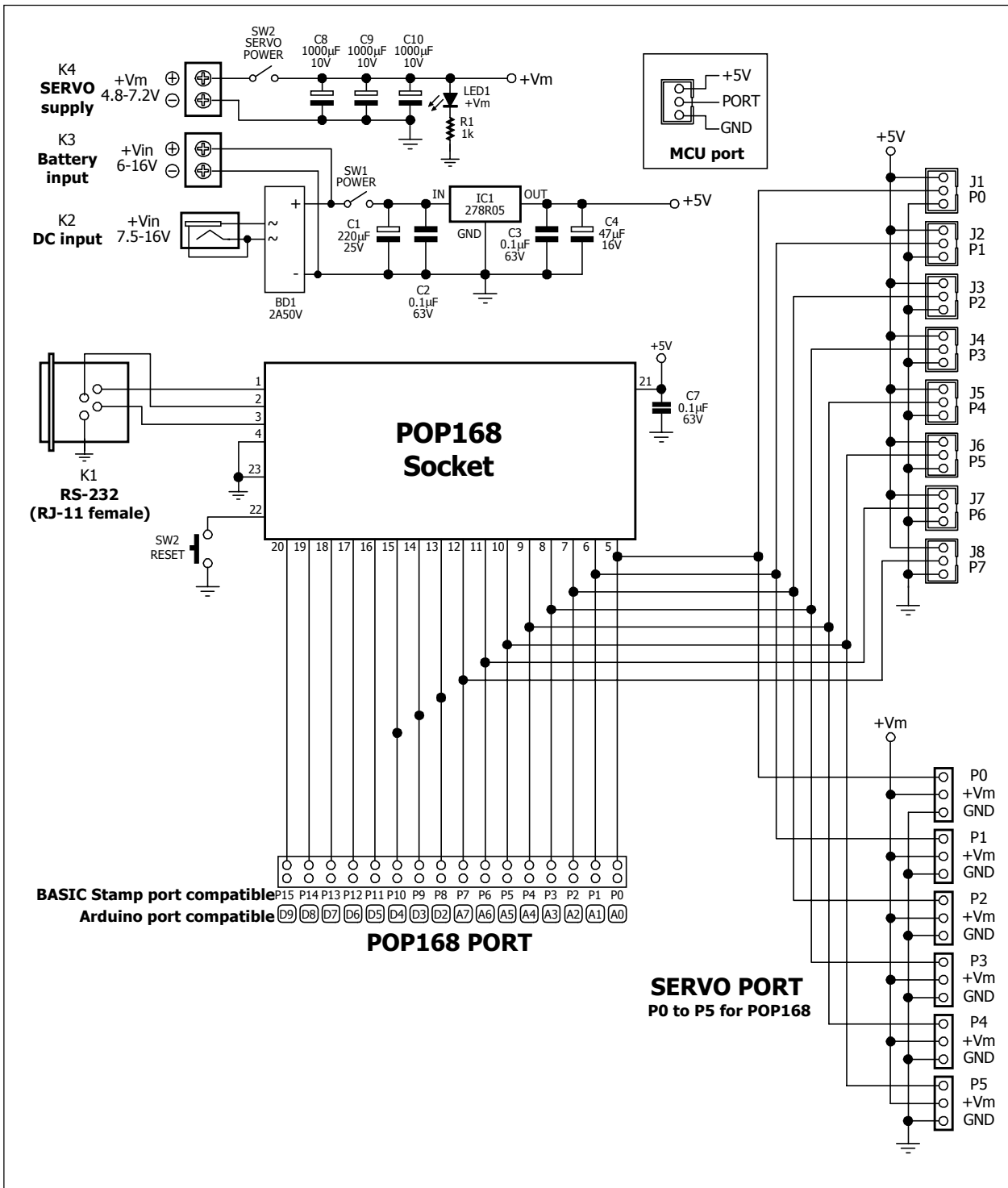

Figure 1 : Schematic of JX-POP168 Project board for POP-168 microcontroller

In addition, the JX-POP168 board provides 6 of servo motor ports. They are connected to P0 to P5 of POP-168 module. The servo motor supply must apply at the +Vm terminal. It is separated from the main supply terminal. The +Vm supply voltage range is +4.8 to +7.2V depend on your servo motor.

3. Using JX-POP168 board with POP-168 module

3.1 Install POP-168 module on female socket following the photo below. Must installation right direction for protection POP-168 damage.



3.2 Connect JX-POP168 board to serial port with CX-4 cable. If your computer has not Serial port, you can use the USB to RS-232 Serial converter board (UCON-232S is recommended).

3.3 Supply voltage to JX-POP168 board. See LED "ON" at POP-168 module turn-on.

3.4 After download and install Arduino software on machine (free download at www.arduino.cc), configuration must be choose on the first times. Run "Arduino" program, Set microcontroller type, by menu : **Tools** → **Microcontroller (MCU)** → **atmega168** (since Release 0010, this sub menu was changed to "Board" select instead , set **Board** → **Arduino Mini** or **POP-168**)

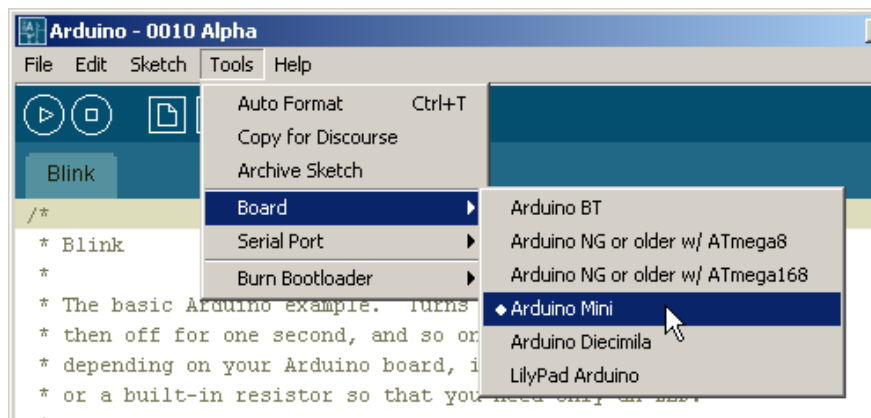

4 ● JX-POP168 : POP-168 microcontroller Project board

3.5 Set communication port, on menu : **Tools** → **Serial Port** → **COM** to select the COM port as POP-168 present.

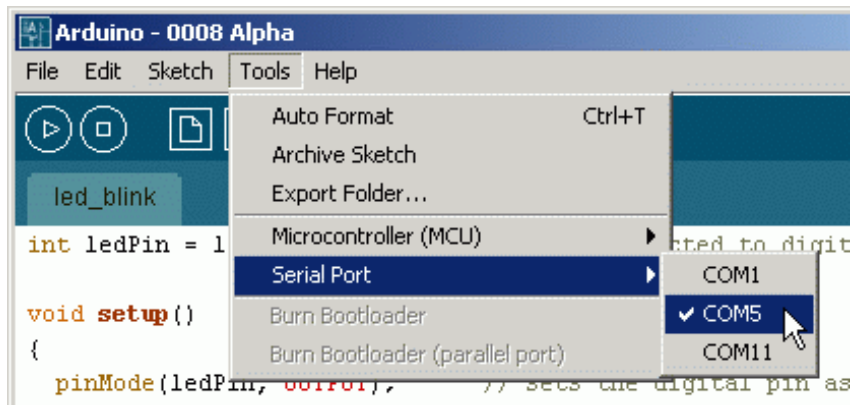

3.6 Open LED demo blinking example, on menu : **File** → **Sketchbook** → **Examples** → **Digital** → **Blink** to select "Blink" demo sketch.

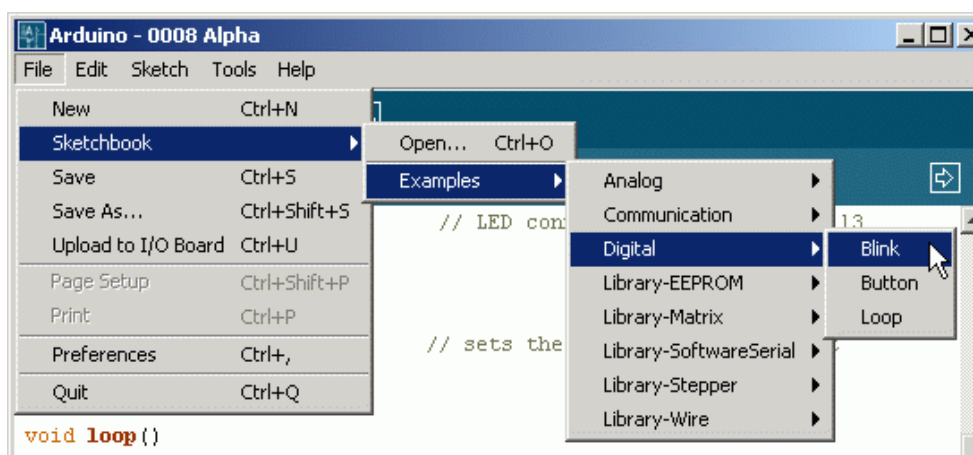

3.7 Then prepare POP-168 into Bootloader

- Power off POP-168
- Hold BL switch , then Power on POP-168
- Release BL switch

If Blue LED on POP-168 was lighted and not blink, then POP-168 had entered Bootloader mode and ready to uploaded.



3.8 Click Upload button on Arduino's toolbar

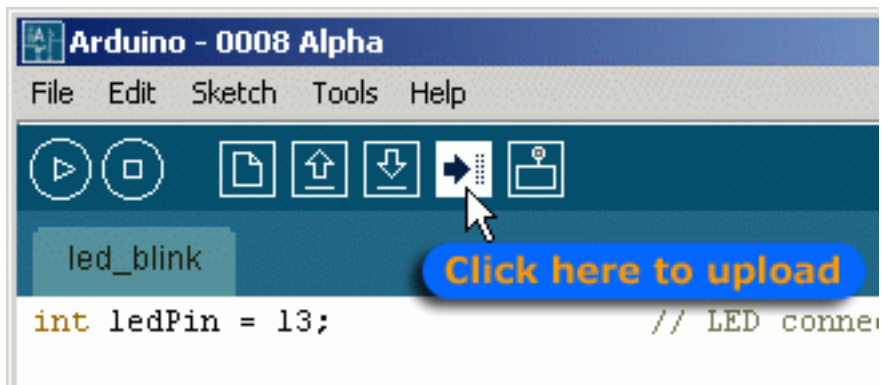

3.9 Wait for a while.. above Arduino's console will shown message if uploaded sketch finish "Done uploading", the red message was shown on Arduino 0008 and earlier only , on 0009 and newer had no these red message.

```

Done uploading.
Binary sketch size: 1108 bytes (of a 14336 byte maximum)
Atmel AVR ATmega168 is found.
Uploading: flash
Firmware Version: 1.15
Firmware Version: 1.15
2
    
```

3.10 After download complete, Reset the board again and check out your code running. Enjoy your work !!

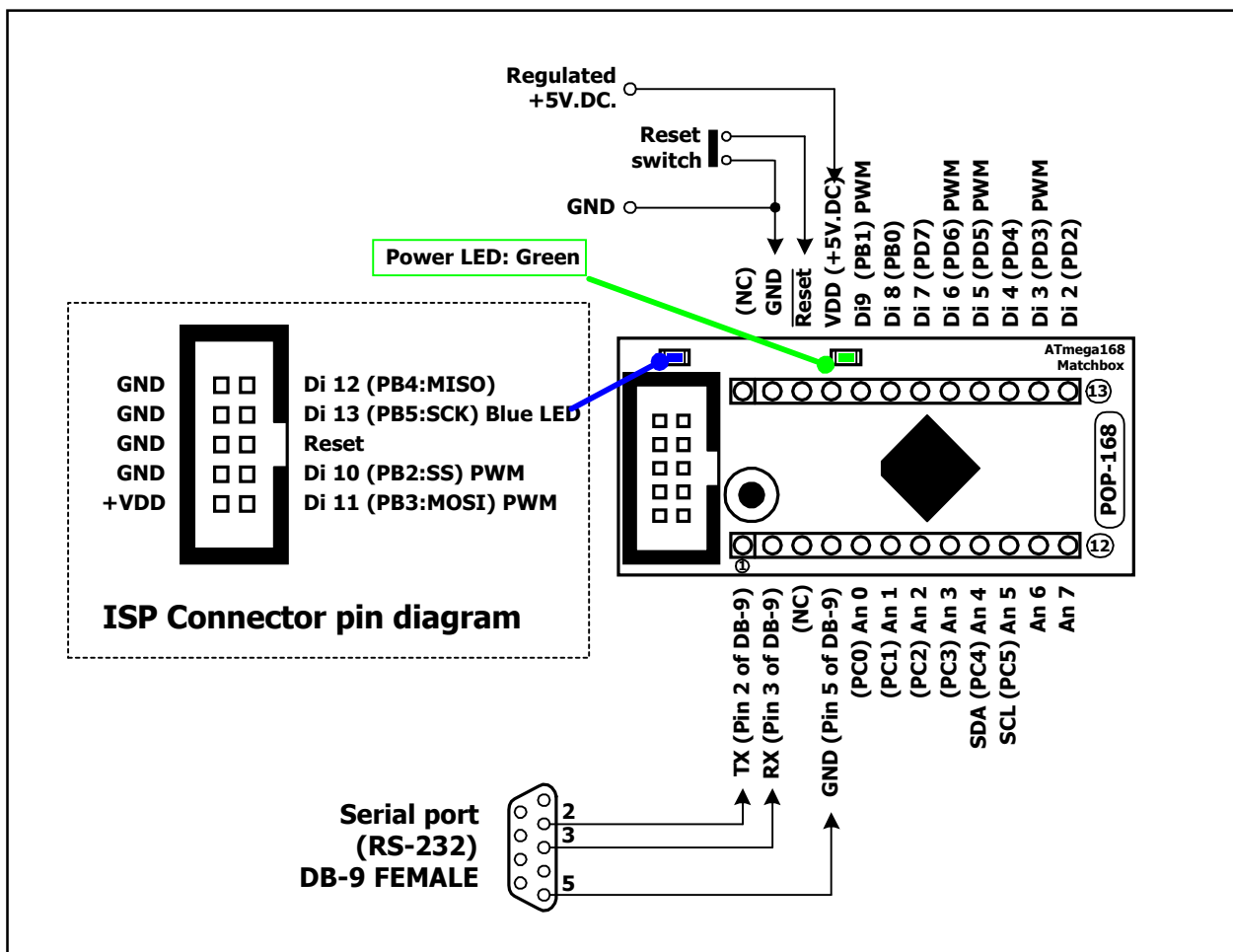

Figure 2 : POP-168 ATmega168 Matchbox microcontroller module pin-out

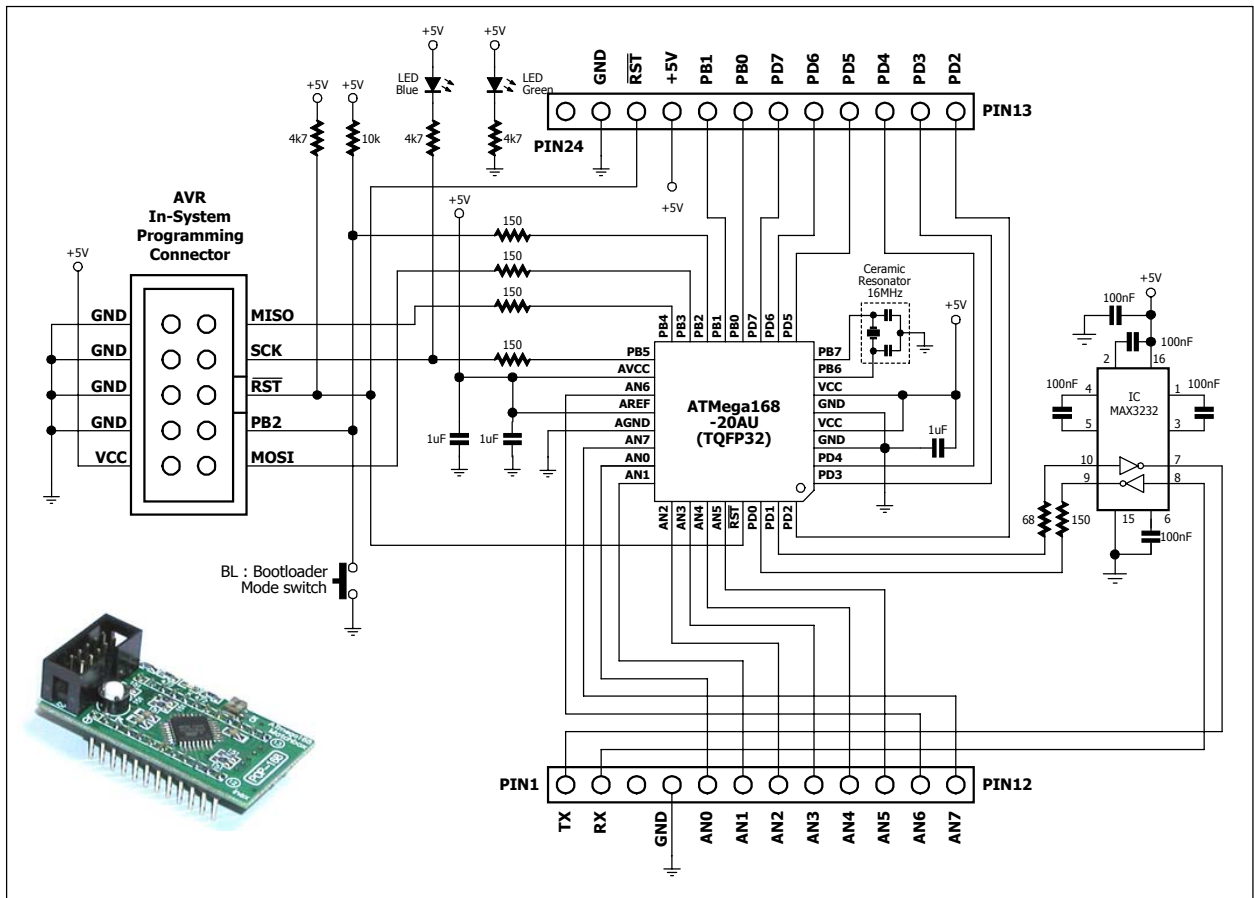

Figure 3 : POP-168 schematic diagram (This module is not included in the JX-POP168 set)

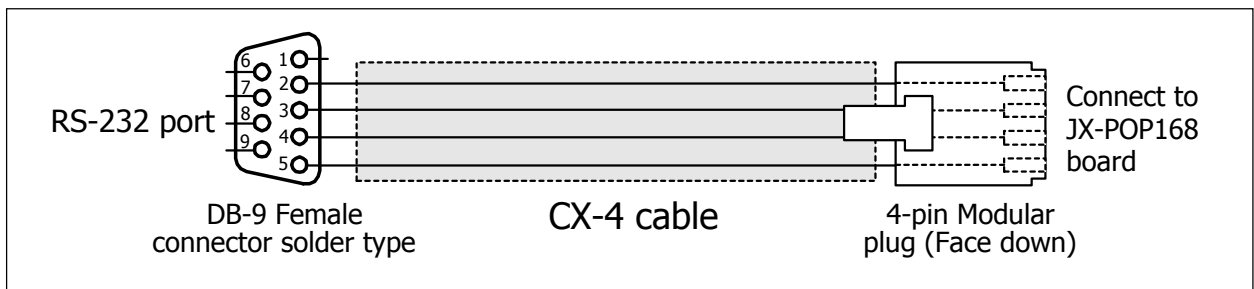

Figure 4 : CX-4 cable connection diagram

4. The related software tools

- Arduino (www.arduino.cc)
- POP-Loader : Bootloader utility for POP-168 (www.avride.com/pop/)
- AVR Studio : Official AVR microcontroller development tools (www.atmel.com)
- WinAVR : Open source software development tools for the Atmel AVR (<http://winavr.sourceforge.net/>)

5. The related products

- POP-168 ATmega168 Matchbox microcontroller module
- POP-Interface board
- DC adaptor (+6Vdc 500mA or higher and +12Vdc maximum)
- UCON-232S the USB to RS-232 Serial port converter
- Varieties of sensors and application board from inex (www.inex.co.th) and RC Servo motors.

